

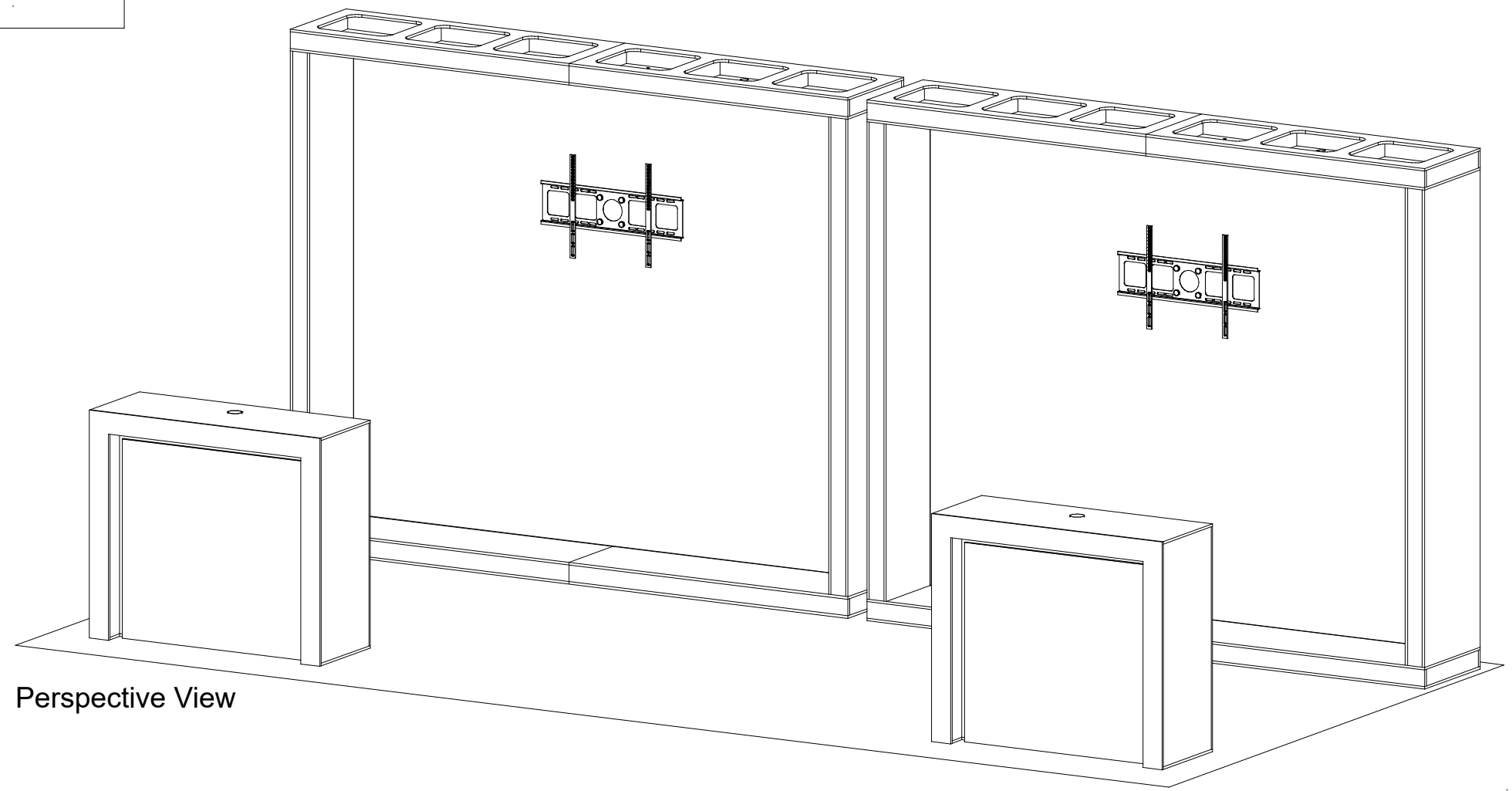

Plan View

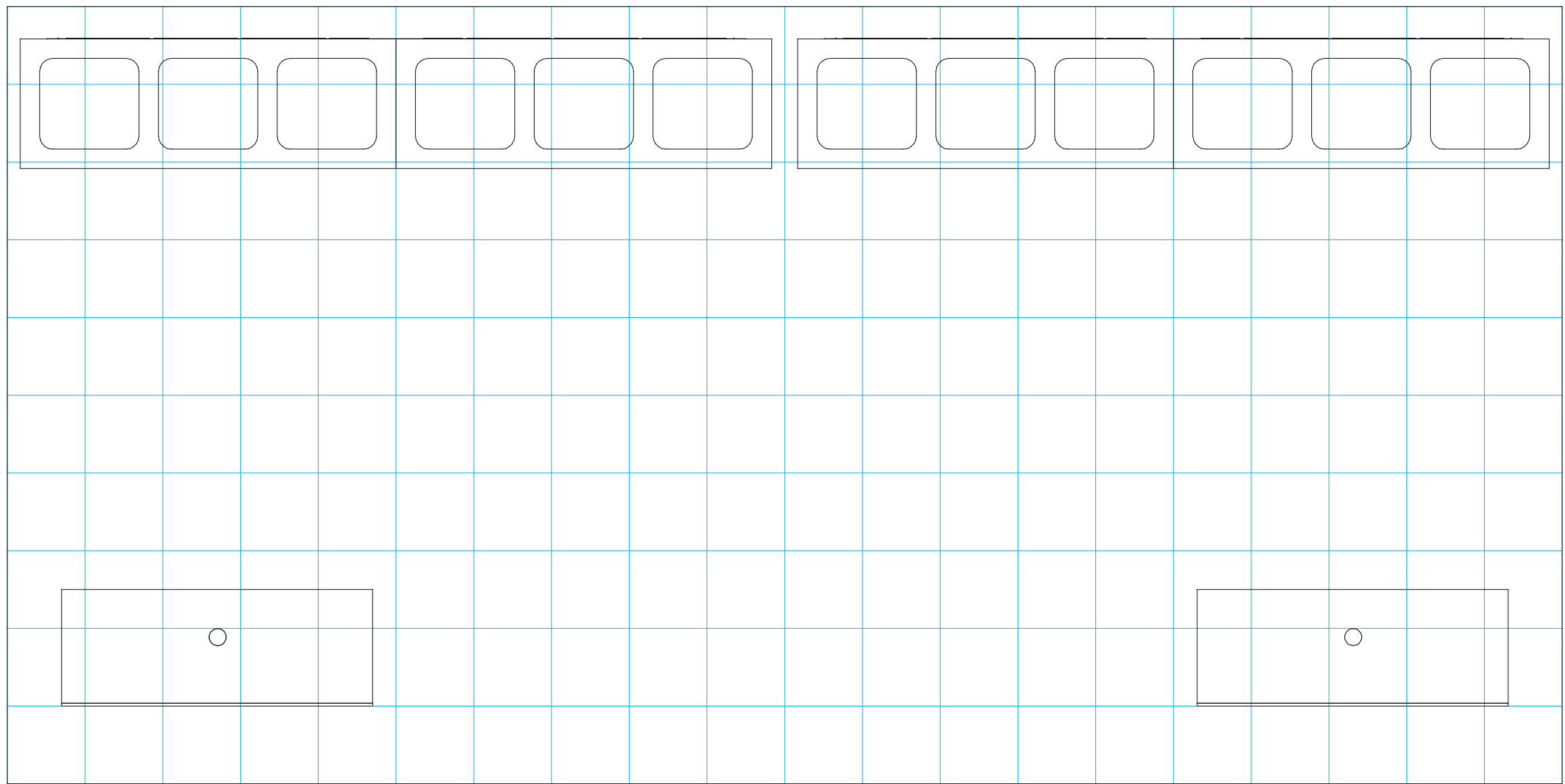

Perspective View



 = 1 sq foot

General Setup Instructions

- Read entire setup instruction manual prior to unpacking parts and pieces.
- The setup instructions are created specifically for this configuration.
- Setup instructions are laid out sequentially in steps, including exploded views with detailed explanation for assembly.

Cleaning & Packing

- For Cleaning Metal, Plex, & Laminate Parts: Use a **MILD NON-ABRASIVE** cleanser and soft cloth/paper towel to clean all surfaces.
- Keep exhibit components away from heat and prolonged sun exposure. **Heat and UV exposure will warp and fade components.**
- Retain all provided Packing Materials. All provided packing materials are for ease of repacking & component protection.

Disassembly

- For loss prevention, tighten all set screws and locks during disassembly.

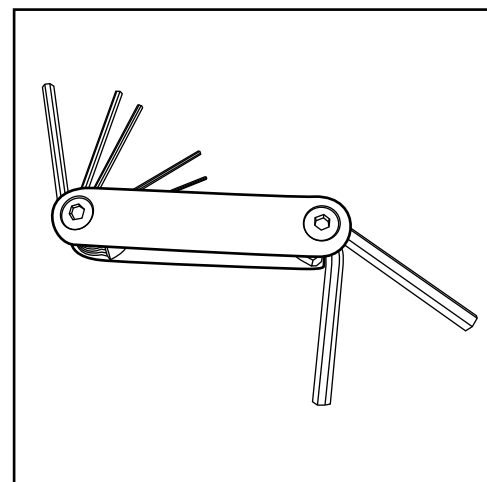

Hex Tool - Essential for Assembly

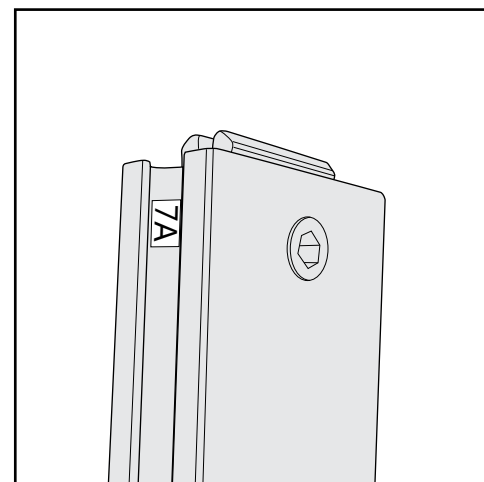

Part Identification - Numbering

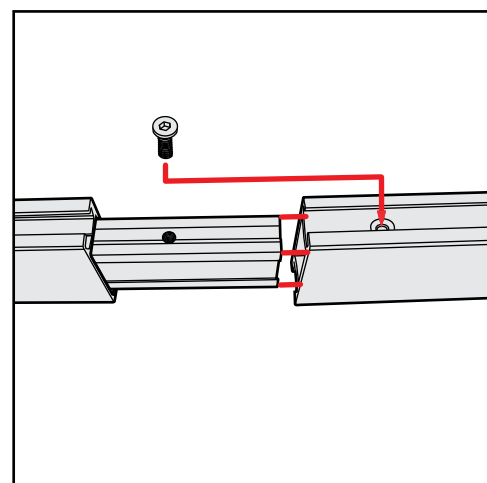

Spline Connection

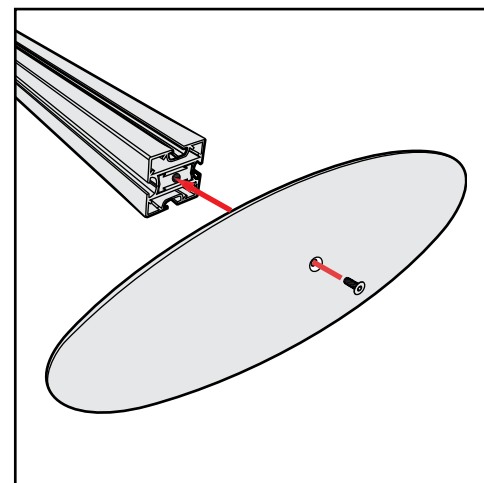

Base Plate & Extrusion Connection

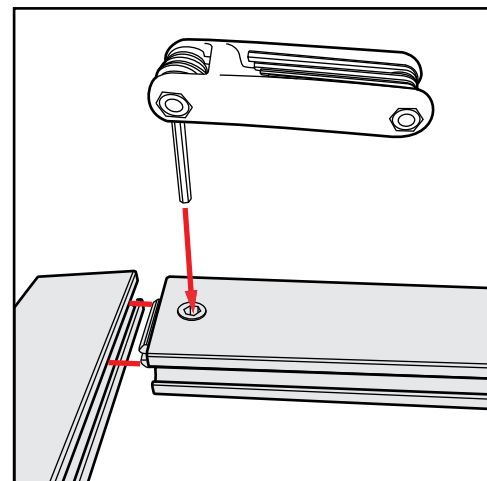

Extrusion & Lock Connection

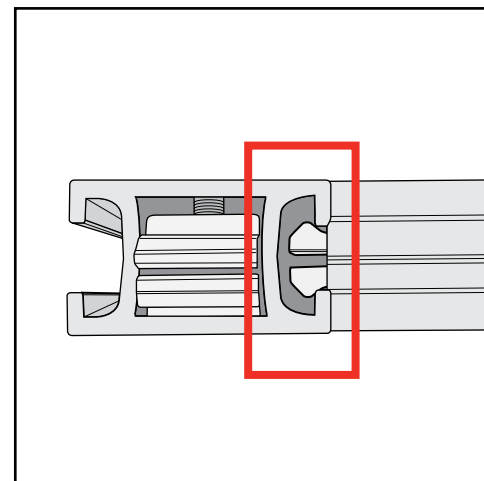

Engaged Lock



WARNING

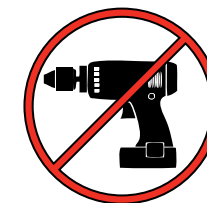

DO NOT USE POWER TOOLS

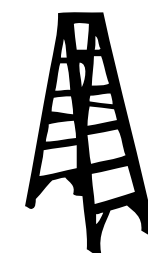

LADDERS OR LIFTS
MAY BE REQUIRED



ALL CONNECTIONS MUST
BE TIGHTLY SECURED

Corner Bracket Assembly

- 1) Slide TWO-PIECE **TS RV 2** L-bracket into Interior Center Slot of extrusion so that two set screws are inside groove. Tighten two set screws to secure.
- 2) Slide one **A1** L-Bracket into outer interior grooves of upper and lower horizontals. Tighten set screws to secure.
- 3) Slide vertical extrusion over exposed ends of brackets in lower horizontal. Tighten set screws to secure.
- 4) Slide exposed ends of installed brackets of upper horizontal into open ends of verticals. Tighten set screws to secure.

Disassembly

- 1) Loosen set screws on brackets and slide extrusions off of brackets.

Corner Connection

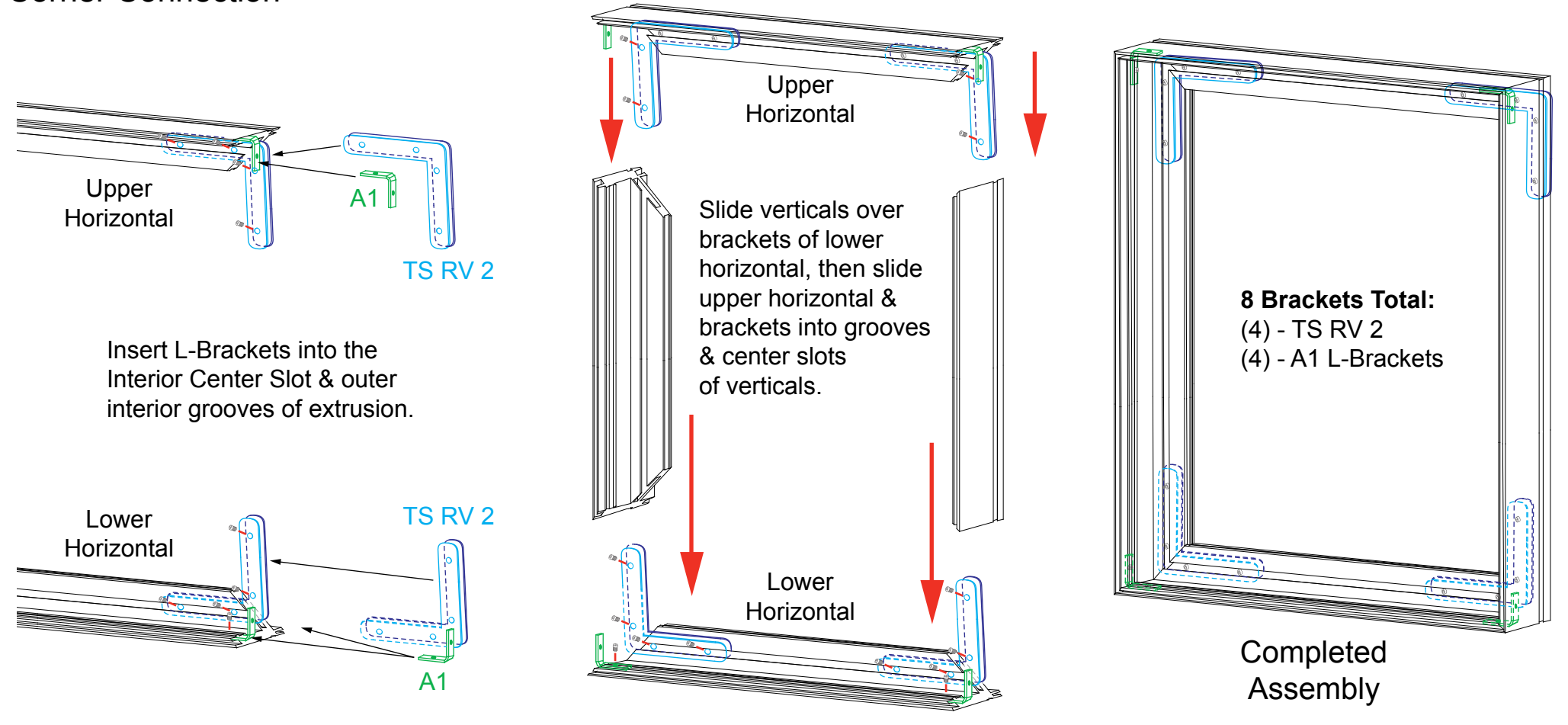

Straight Bracket Assembly

- 1) Slide TWO-PIECE **TS RV 4** straight bracket into Interior Center Slot of extrusion, so that two of the set screws are inside groove. Tighten two set screws to secure.
- 2) Slide one **V4 Connector** into outer interior groove of extrusion, so that one set screw is inside groove. Tighten set screw.
- 3) Slide connecting extrusion over exposed ends of bracket & connector. Tighten all remaining set screws to secure extrusions.



Straight Connection

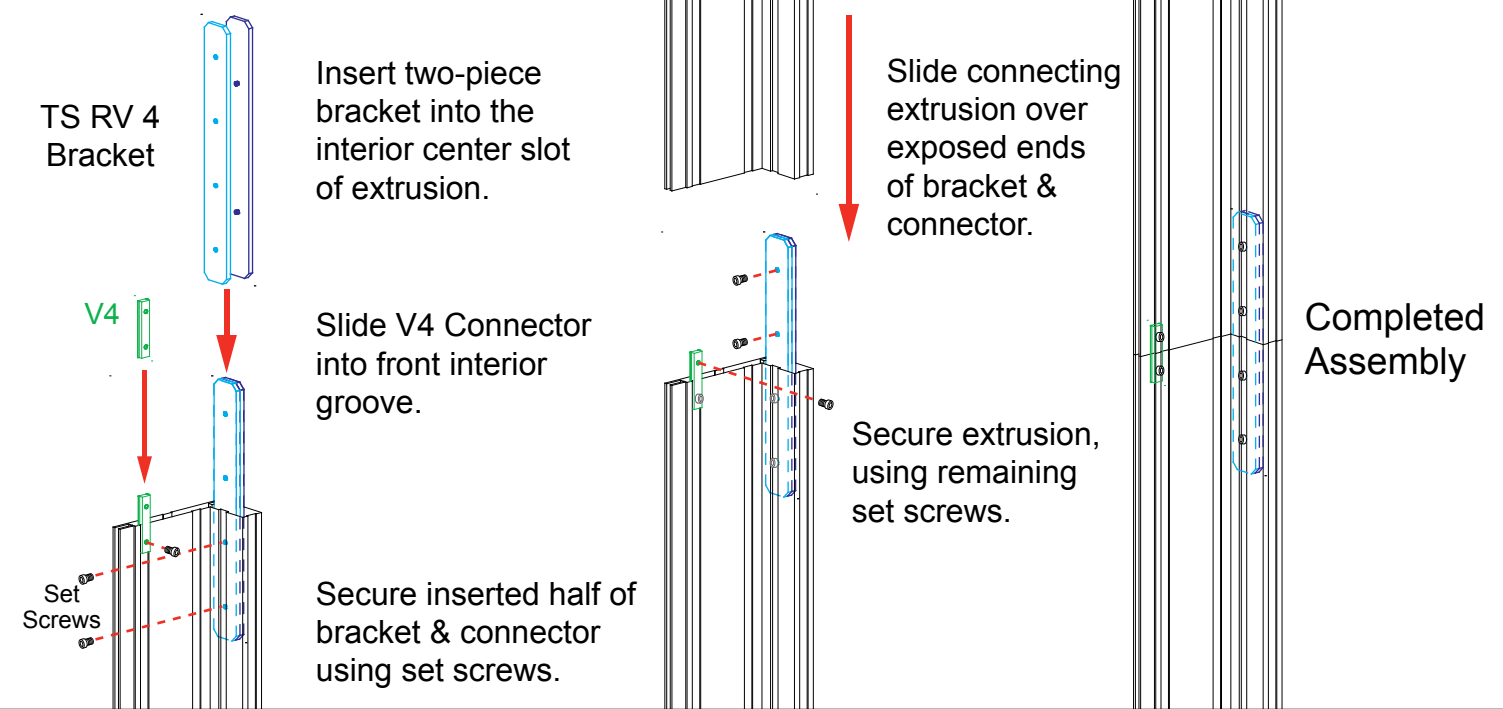

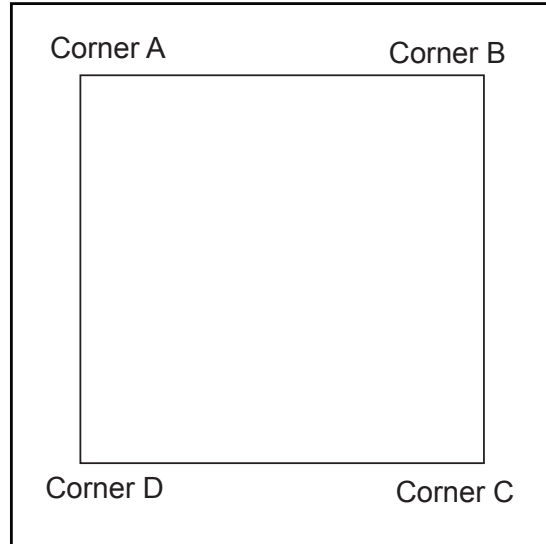

It is important to first insert graphic into each alternate corner then to the sides of the frame. If this is not done, graphic will not fit into the frame correctly.

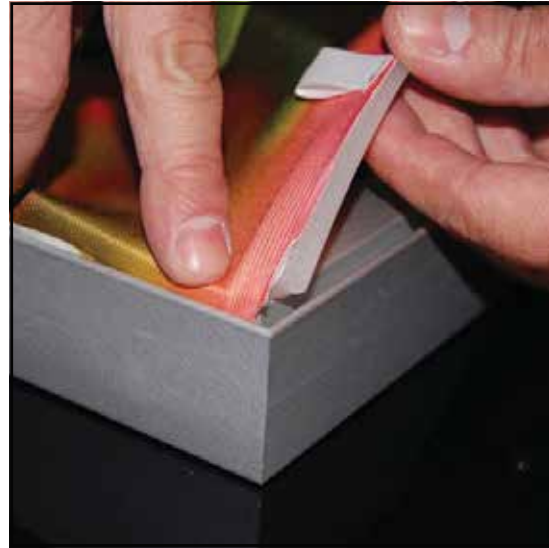

Step 1
Insert corner A. Turn edge of graphic so silicon welt is perpendicular to face of graphic. Insert narrow side of welt with fabric to outside into the channel. Repeat for other side of this corner.



Step 2
Repeat Step 1 for opposite corner C, then insert corner B, followed by corner D, to complete the installation of the corners.



Step 3
Once all corners are inserted, press one silicon edge into channel from corners and work toward the center. Make sure welt is fully inserted into channel. Continue until all sides are done. Smooth out edges of graphic.

Graphic Removal

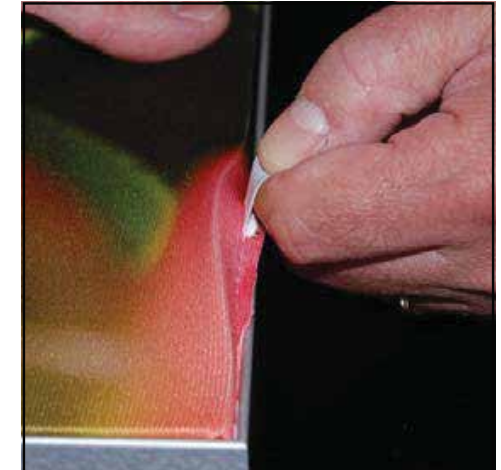

To remove the graphic from the frame, locate the fabric pull tab. Gently pull up on the tab to remove the fabric.

CRATE PACKING

Item	Qty.	Description
1	2	88”h CEI110 Vertical Extrusion
2	2	88”h CEI110 Vertical Extrusion
3A,3B	2,2	54”w CEI110 Horizontal Extrusion
4A,4B	2,2	54”w CEI110 Horizontal Extrusion
5	2	84.353”h Z140 Vertical Extrusion

- Steps:
- 1) Connect horizontals [3A to 3B] and [4A to 4B].
See [CEI-110 Straight Connection](#) detail.
 - 2) Attach horizontal assemblies [3A/3B] and [4A/4B] between verticals [1] and [2].
See [CEI-110 Corner Connection](#) detail.
 - 3) Attach standoffs to vertical [5] then attach [5] between horizontal assemblies.
 - 4) Connect lighting cords and attach transformers.
See [Light to Light Connection](#) & [Light to Transformer Connection](#) details.

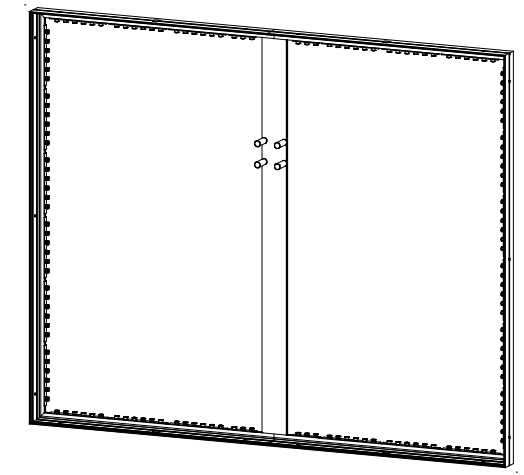

Completed Assembly

Repeat steps 1 through 4 for other frame assembly.

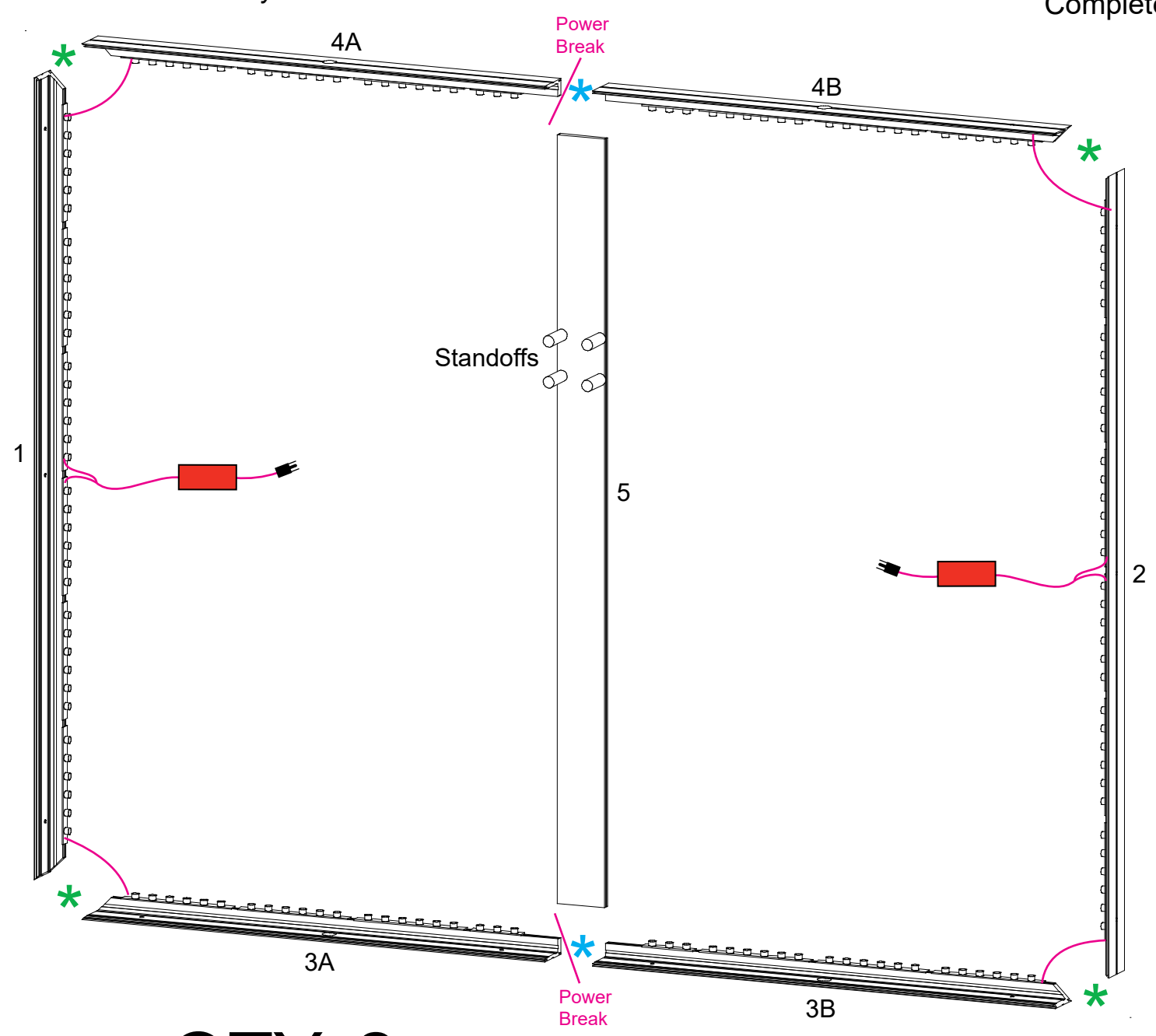
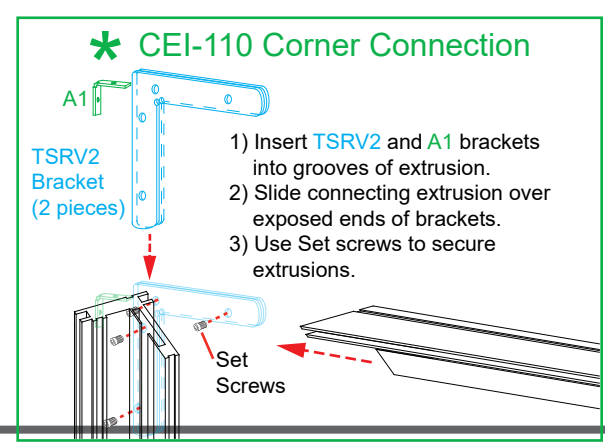
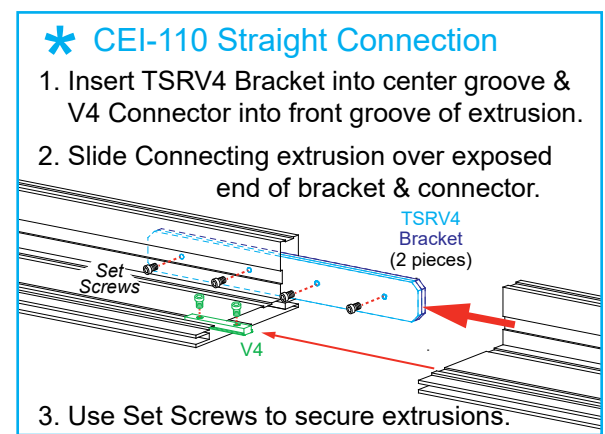
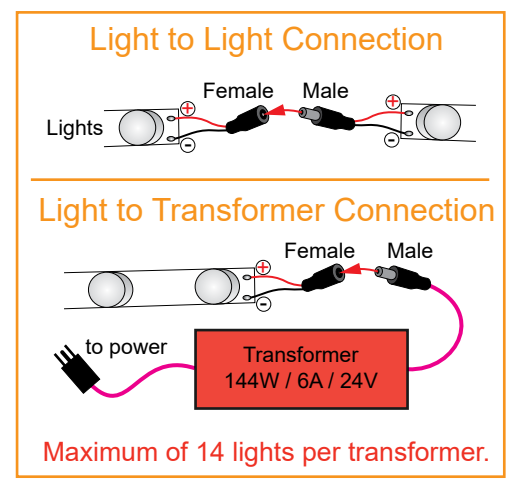

QTY. 2

Item	Qty.	Description
D/D1	2,2	53"w x 20"d x 4" Wood Panel
E/E1	2,2	88"w x 20"d x 4" Wood Panel
G/G1	2,2	53"w x 20"d x 4" Wood Panel

- Steps:
- 1) Assemble wood panels as shown. See **Cam Lock Connection** detail.
 - 2) Attach assembled lightbox to wood panels using washers & bolts.
 - 3) Install SEG graphic to assembled lightbox.
See SEG Graphics Installation sheet for details.
 - 4) Attach monitor mount to standoffs on extrusion [5] using caps.
- Repeat steps 1 through 4 for other frame assembly.*

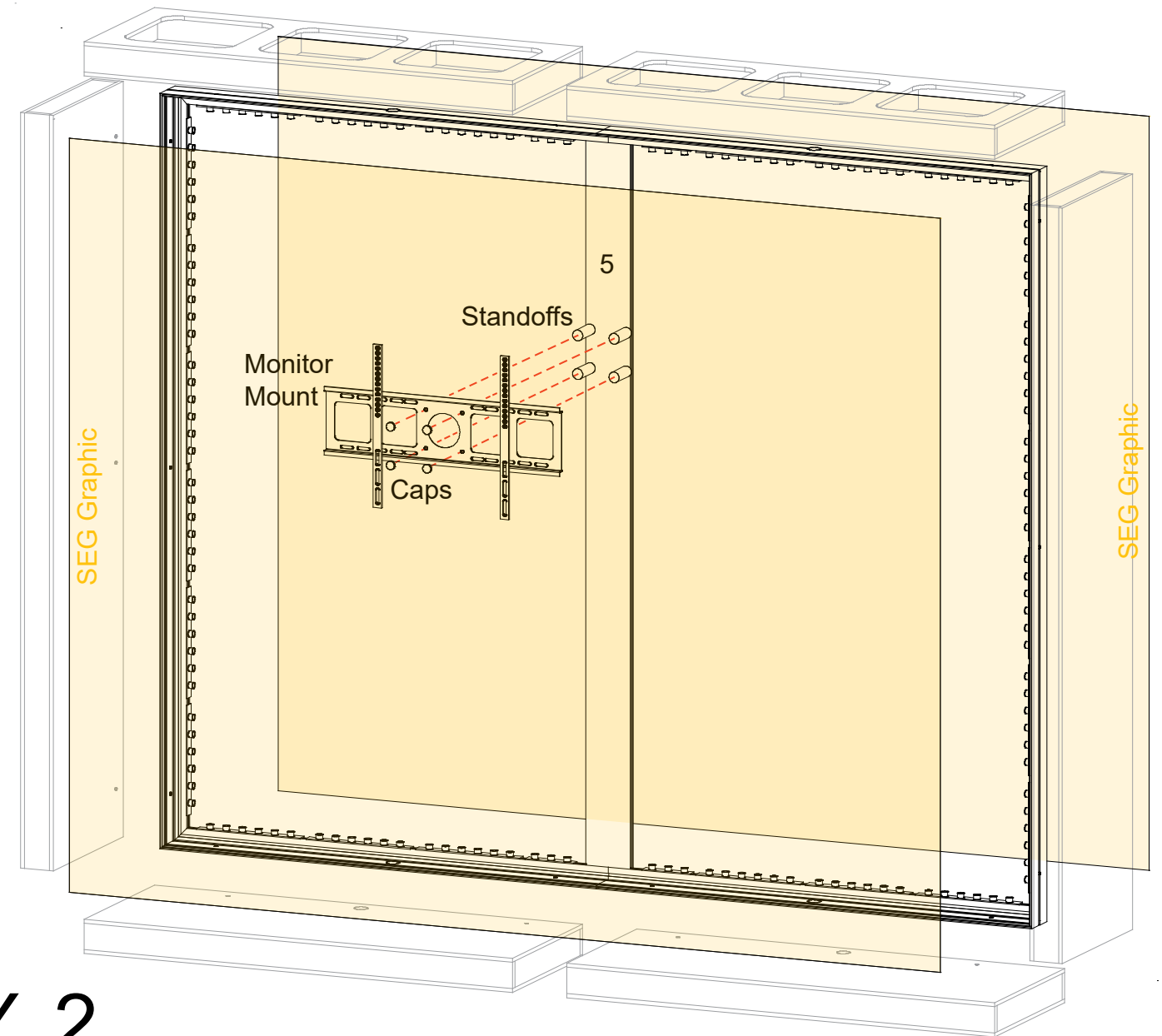
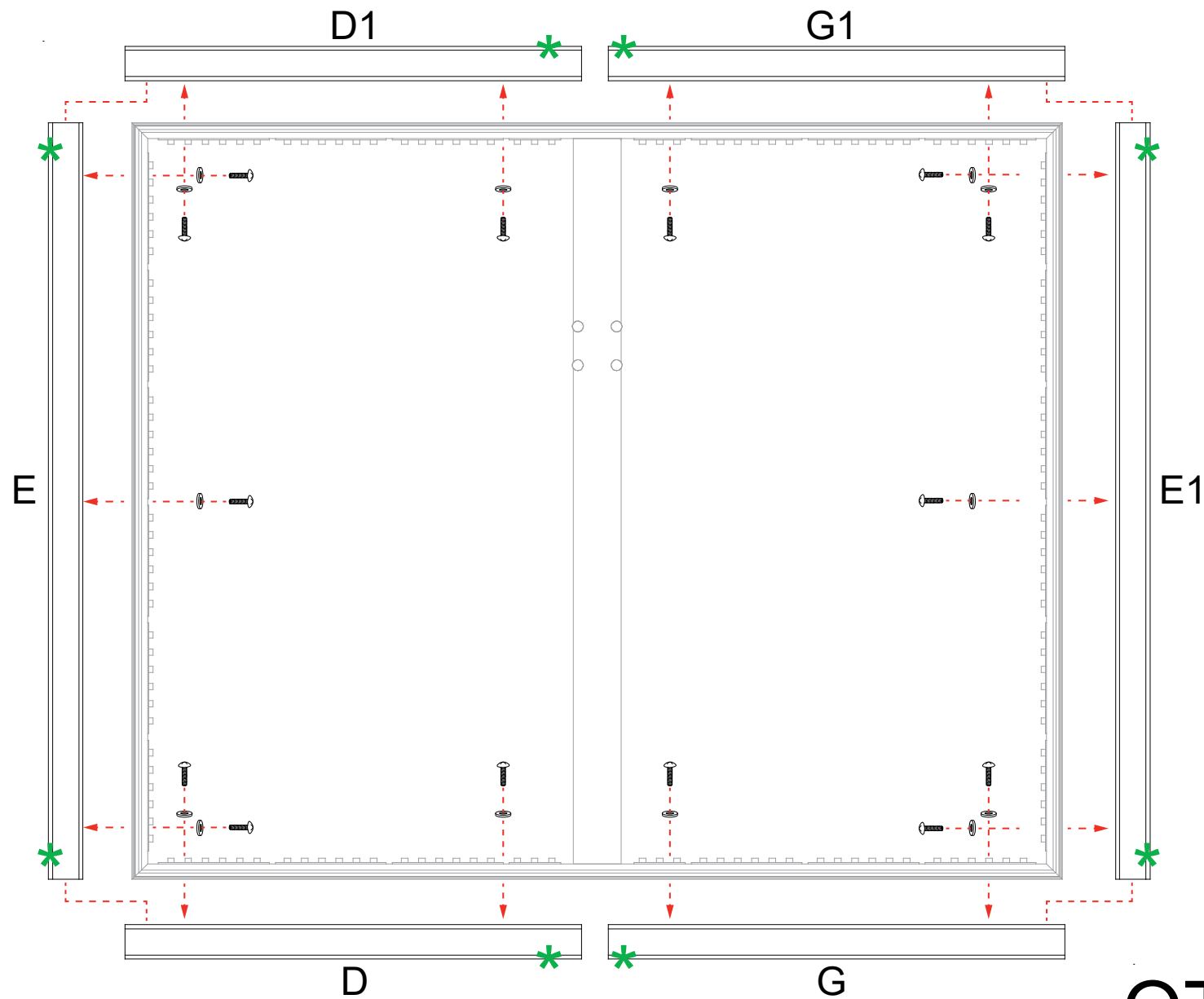
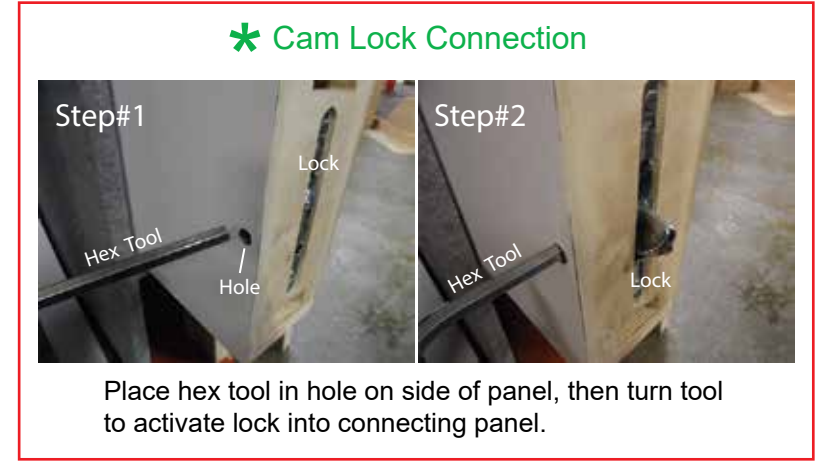

QTY. 2

Steps:

- 1) Attach transformer. See [Light to Light Connection](#) & [Light to Transformer Connection](#) details.
- 2) Route cord thru hole in base of counter then connect to power.

Light to Light Connection

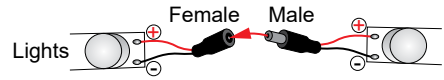

Light to Transformer Connection

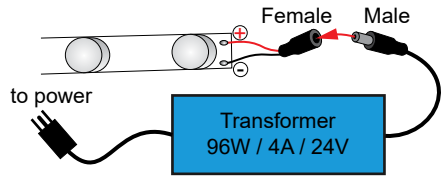

Maximum of 9 lights per transformer.



Optional Lighting

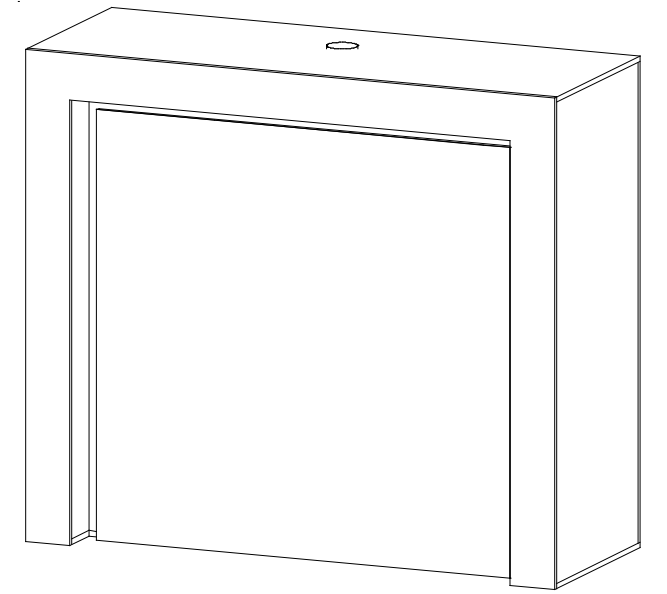

Completed Assembly



All cords and transformer stay attached.

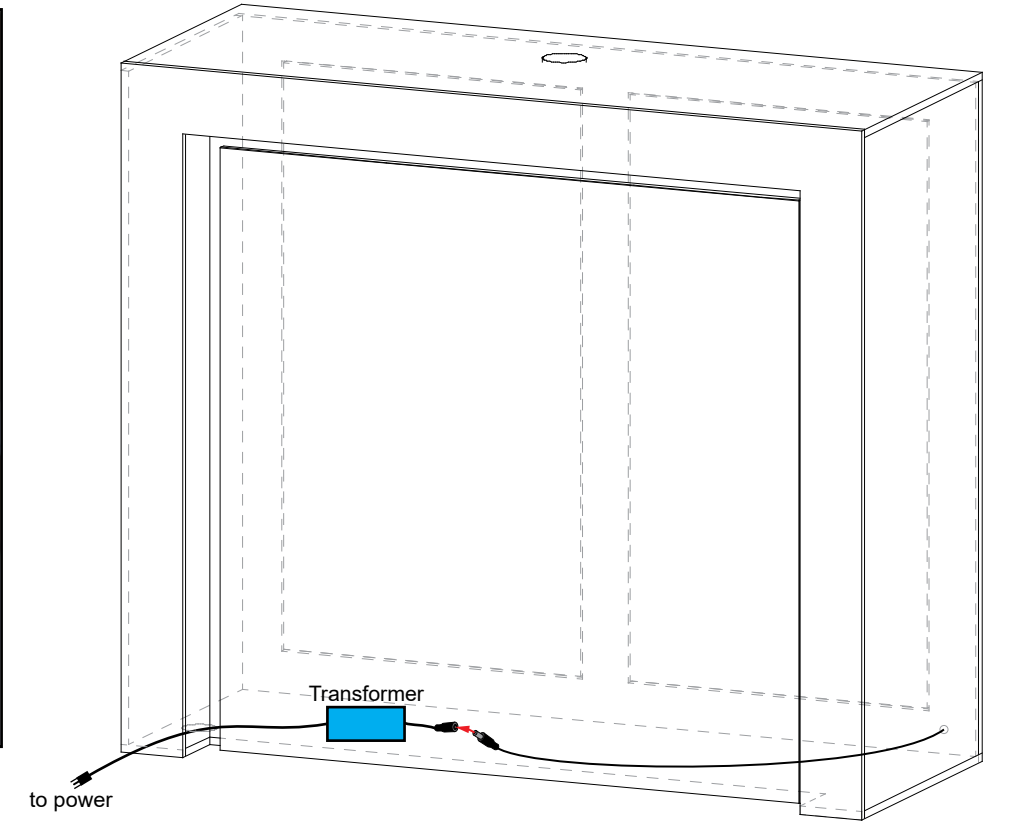

QTY. 2